

High voltage Isolation amplifier Signal conditioner

CNL34DHig **LOREME**

- **Process and temperature input**
platinum RTD, thermocouple,
mV (shunt), mA
- **High voltage galvanic isolation**
dielectric strength of 10kVac / 15kVdc continuous
- **Fully configurable**
RS232 link
- **Universal power supply Ac / Dc**

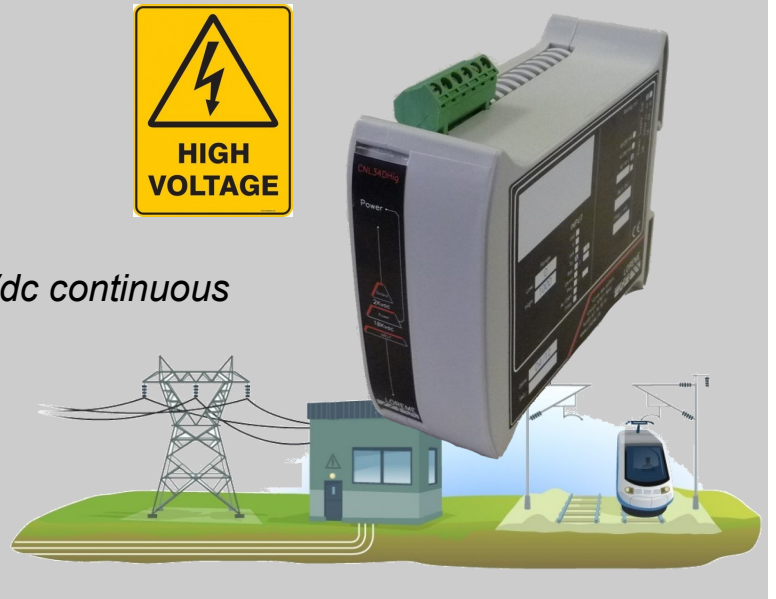

CNL34DHig is a transmitter for applications on high voltage environment (transformer, motors, alternators,...). Environment having need a maximal safety.

FUNCTIONALITIES:

Temperature inputs:

- Thermocouples with linearization and internal cold junction compensation,
- platinum RTD probe (2 or 3 wires mount) with linearization and line length compensation.

Process inputs:

- voltage (mV), from current measure shunt.

Signal processing:

- user defined sensor breaking security value,
- programmable response time 0.2 to 60 seconds (adjustable damping)
- normal or reverse output,
- offset measure adjustment,
- low sensibility to thermal ambient variations.

Implementation:

- Symmetrical DIN rail mounting,
- pluggable screw terminal block (2.5 mm²),
- universal power supply Ac / Dc,
- RS232 link for configuration,
- parameters saving on Flash, data retention > 30 years,
- input / output / power supply galvanic isolation (creepage distance for input circuit > 20mm), dielectric strength of 15kVac, 20kVdc for 1 minute,
- High voltage conformal coating,
- protection class (house/terminal block) : IP20.

CONFIGURATION:

The device is configurable via the RS 232 serial link (jack 3.5) with any system emulating terminal.
No specific software required.
USB - jack 3.5 cable available separately.

Through terminal, user will be able to:

- visualize measure,
- setup device,
- adjust the offset measure.

Synoptic:

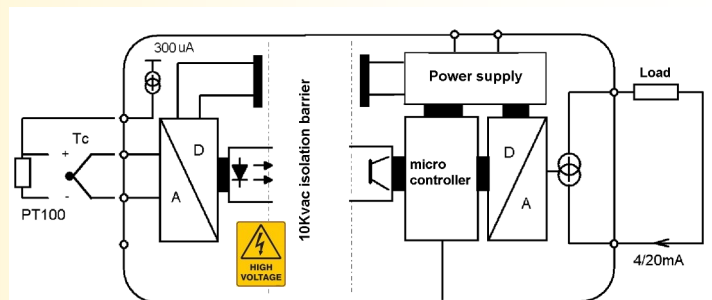

Version and code order :

[Request a quote](#)

CNL34DHig : Temperature and mV input model
insulation: 10kVac/ 15kVdc, response time: 200ms.
Universal power supply

CNL34DTHig mV / V input model
insulation 10kvac/15kVdc, response time: 1 ms
Universal power supply

INPUT (24 bits resolution)		
TYPE	RANGE	ACCURACY
Tc B	200 / 1800 °C	+/- 2 °C
Tc E	-250 / 1000 °C	+/- 0.4 °C
Tc J	-200 / 600 °C	+/- 0.4 °C
Tc K	-200 / 1350 °C	+/- 0.4 °C
Tc R	0 / 1750 °C	+/- 1 °C
Tc S	0 / 1600 °C	+/- 1.5 °C
Tc T	-250 / 400 °C	+/- 0.5 °C
Tc W5	0 / 2300°C	+/- 2°C
Other thermocouple on request		
T° Compensation	-20 / 60 °C	+/- 0.3 °C
Input impedance		> 1 MOhms
breaking current detection:		0.25µA
2, 3 wires RTD	-200 / 800°C	+/- 0.3 °C
Excitation current		300 µA
Cable influence		< 0.03°C / Ohms
(maximum cable resistance: 10 ohms by wires)		
Voltage	0 / 120 mV	+/- 0,02 mV
other voltage on request		
Input impedance		> 1 MOhms
Current	0 / 30 mA	+/- 0,015 mA
on external shunt	2,5 Ohms (provided on request)	
POWER SUPPLY		
Universal: (2 versions: standard and low voltage, not polarized)		
standard : 20...to...265Vac/dc		
low voltage : 9...to...30Vdc.		
consumption < 3 VA		

OUTPUT (12 bits resolution)		
Type	Range	Accuracy
Current	0...4...20 mA	± 20µA
Permissive load:	0...850 Ohms	
Voltage	0...10 V	± 10mV
Output impedance:	500 Ohms (0.1% internal shunt)	
Programmable response time from 200ms to 60s		
ENVIRONMENT		
Dielectric strength Input / Ouput		10kV rms continuous
Dielectric strength Input / Supply		10kV rms continuous
Dielectric strength Output / Supply		2.5kV rms continuous
Operating temperature:		-10 to 60 °C
Storage temperature:		-20 to 85 °C
Influence:		< 0.01 % / °C
		(% full scale)
Humidity:		85 % not condensing
Weight:		220 g

Electromagnetic compatibility 2004/108/CE / Low Voltage Directive 2006/95/EC

Immunity standard for industrial environments EN 61000-6-2		Emission standard for industrial environments EN 61000-6-4
EN 61000-4-2 ESD	EN 61000-4-8 AC MF	EN 55011
EN 61000-4-3 RF	EN 61000-4-9 pulse MF	group 1 class A
EN 61000-4-4 EFT	EN 61000-4-11 AC clips	
EN 61000-4-5 CWG	EN 61000-4-12 ring wave	
EN 61000-4-6 RF	EN 61000-4-29 DC clips	



WIRING AND OUTLINE DIMENSIONS:

